

Q1. Bayes Nets: Elimination

(a) Consider running variable elimination on the Bayes Net shown below.

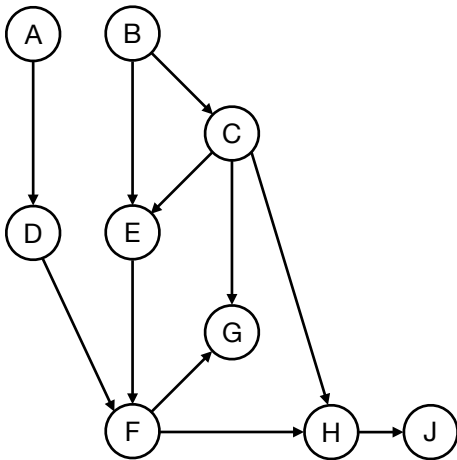

First, we eliminate D to create a factor f_1
 Next, we eliminate E to create a factor f_2
 Next, we eliminate H to create a factor f_3

From the list below, select all factors that remain after D , E and H have been eliminated.

- f_1
- f_2
- f_3

- $P(A)$
- $P(A|F)$
- $P(B)$
- $P(B|A)$
- $P(B|C)$
- $P(C)$
- $P(C|B)$

- $P(D|A)$
- $P(D|A, F)$
- $P(E|B)$
- $P(E|C)$
- $P(E|B, C)$
- $P(F)$
- $P(F|A, B)$
- $P(F|G)$

- $P(G|C)$
- $P(G|C, F)$
- $P(H|F)$
- $P(H|C, F)$
- $P(H|J)$
- $P(J|C)$
- $P(J|F)$
- $P(J|H)$

(b) Consider the Bayes Net shown below. Each variable in the Bayes Net can take on two possible values.

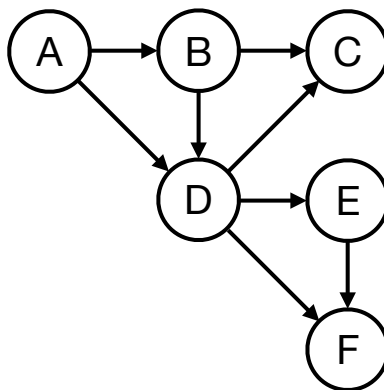

You are given the query $P(C|F)$, which you would like to answer using variable elimination. Please find a variable elimination ordering where the largest intermediate factor created during variable elimination is as small as possible.

Elimination ordering: _____

- (c) Consider doing inference in an $m \times n$ lattice Bayes Net, as shown below. The network consists of mn binary variables $V_{i,j}$, and you have observed that $V_{m,n} = +v_{m,n}$.

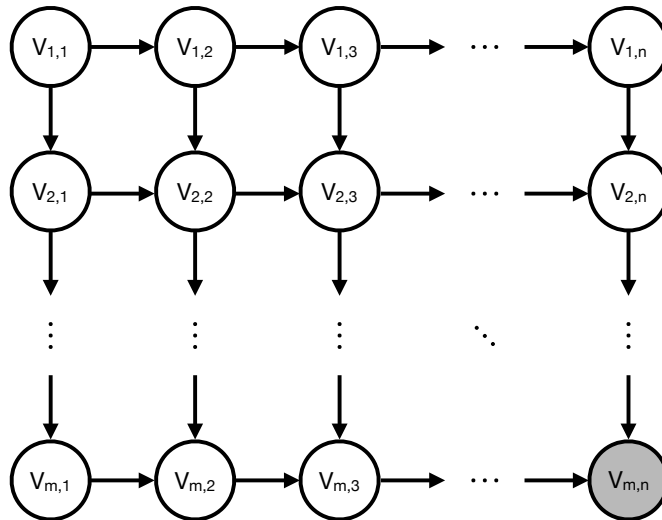

You wish to calculate $P(V_{1,1} | +v_{m,n})$ using variable elimination. To maximize computational efficiency, you wish to use a variable elimination ordering for which the size of the largest generated factor is as small as possible.

- (i) First consider the special case where $m = 4$ and $n = 5$. A reproduction of the lattice is shown below, with variable names for non-query variables omitted. Please provide your optimal elimination ordering for this example by numbering the nodes below in the order they will be eliminated (i.e. write a number such as 1, 2, 3, ... inside every node that will be eliminated.)

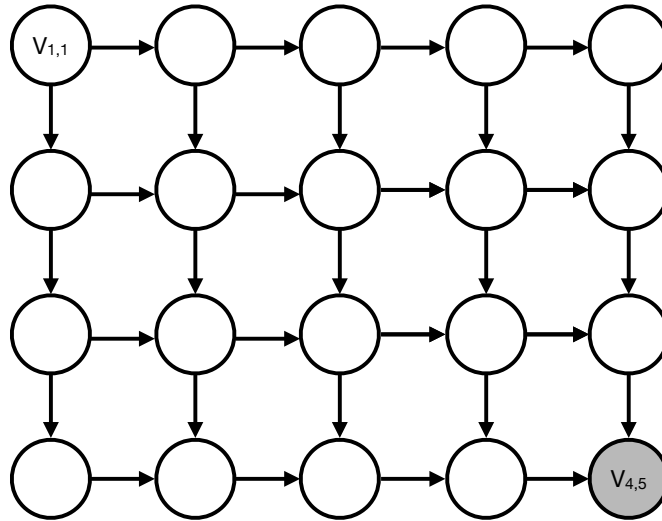

- (ii) Now consider the general case (assume $m > 2$ and $n > 2$). What is the size of the largest factor generated under the most efficient elimination ordering? Your answer should be the number of rows in the factor's table, expressed in terms of m and n .

Size (number of rows) of the largest factor: _____

Q2. Bayes' Nets: Representation and Independence

Parts (a), (b), and (c) pertain to the following Bayes' Net.

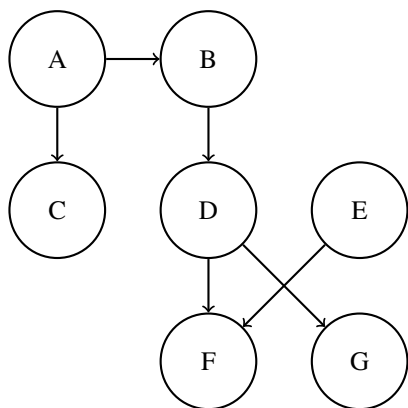

(a) Mark the statements that are guaranteed to be true.

$B \perp\!\!\!\perp C$

$F \perp\!\!\!\perp G|D$

$A \perp\!\!\!\perp F$

$B \perp\!\!\!\perp F|D$

$D \perp\!\!\!\perp E|F$

$C \perp\!\!\!\perp G$

$E \perp\!\!\!\perp A|D$

$D \perp\!\!\!\perp E$

Parts (b) and (c) pertain to the following probability distribution tables. The joint distribution $P(A, B, C, D)$ is equal to the product of these probability distribution tables.

A	$P(A)$	A	B	$P(B A)$	B	C	$P(C B)$	C	D	$P(D C)$
+a	0.8	+a	+b	0.9	+b	+c	0.8	+c	+d	0.25
-a	0.2	+a	-b	0.1	+b	-c	0.2	+c	-d	0.75
		-a	+b	0.6	-b	+c	0.8	-c	+d	0.5
		-a	-b	0.4	-b	-c	0.2	-c	-d	0.5

(b) State all non-conditional independence assumptions that are implied by the probability distribution tables.

(c) Circle all the Bayes net(s) that can represent a distribution that is consistent with the tables given.

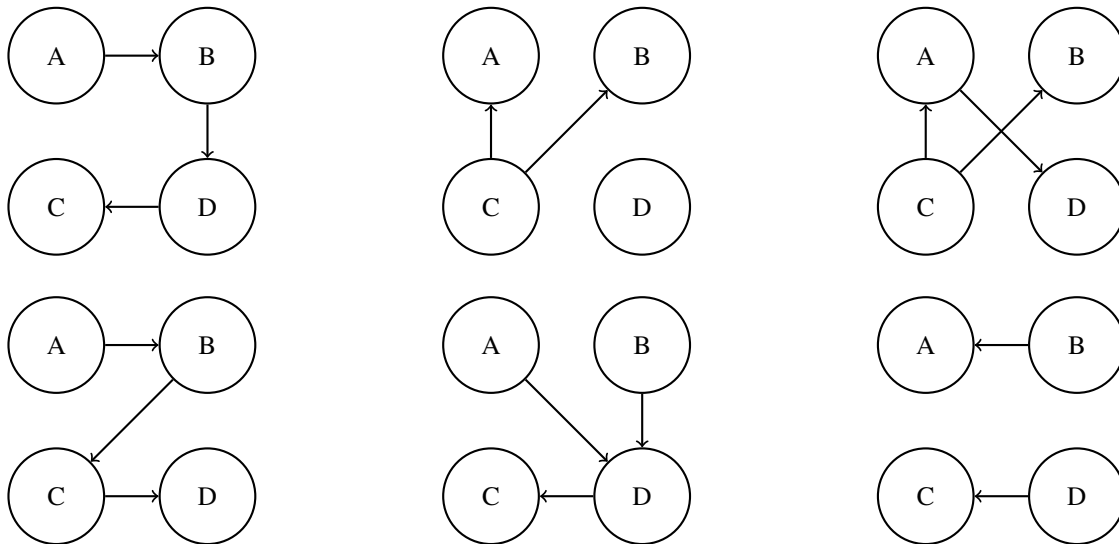

You are building advanced safety features for cars that can warn a driver if they are falling asleep (A) and also calculate the probability of a crash (C) in real time. You have at your disposal 6 sensors (random variables):

- E : whether the driver's eyes are open or closed
- W : whether the steering wheel is being touched or not
- L : whether the car is in the lane or not
- S : whether the car is speeding or not
- H : whether the driver's heart rate is somewhat elevated or resting
- R : whether the car radar detects a close object or not

A influences $\{E, W, H, L, C\}$. C is influenced by $\{A, S, L, R\}$.

(d) Draw the Bayes Net associated with the description above by adding edges between the provided nodes where appropriate.

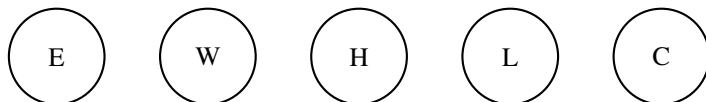
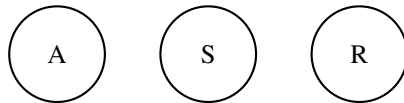

(e) Mark all the independence assumptions that must be true.

$$\square E \perp\!\!\!\perp S$$

$$\square W \perp\!\!\!\perp H|A$$

$$\square S \perp\!\!\!\perp R$$

$$\square E \perp\!\!\!\perp L$$

$$\square L \perp\!\!\!\perp R|C$$

$$\square W \perp\!\!\!\perp R$$

$$\square A \perp\!\!\!\perp C$$

$$\square E \perp\!\!\!\perp C|L$$

(f) The car's sensors tell you that the car is in the lane ($L = +l$) and that the car is not speeding ($S = -s$). Now you would like to calculate the probability of crashing, $P(C|+l, -s)$. We will use the variable elimination ordering R, A, E, W, H . Write down the largest factor generated during variable elimination. Box your answer.

(g) Write down a more efficient variable elimination ordering, i.e. one whose largest factor is smaller than the one generated in the previous question.